



Application Note:
Meeting Military Requirements
for EMI and Transient Voltage
Spike Suppression

By Dr. Glenn Skutt
Vice President of Technology
VPT, Inc.

Meeting Military Requirements for EMI and Transient Voltage Spike Suppression

BACKGROUND: THE EMI AND VOLTAGE TRANSIENT CHALLENGE

Military and aerospace engineers face several challenges with respect to electromagnetic interference (EMI) and transient voltage compliance. The standards developed by the various military organizations are much more stringent than comparable standards in commercial applications, and the standards do not always agree with each other concerning test limits and methods. The intention of an EMI standard is to prevent problems that can arise when electronic noise from one piece of equipment adversely effects the operation of other equipment. Lack of proper EMI control can result in noise interference such as unwanted noise in communication and computing equipment as well as false triggering and faulty readings in sensor circuits.

In addition to noise signals that can cause interference, the normal operation of equipment can result in significant voltage transients that appear on equipment input terminals. These transient voltages are specified by military standards and are tailored for the specific environments encountered by different classes of equipment. For example, land-based equipment can have different requirements than airborne equipment.

One challenge for the military systems designer, therefore, is to address EMI and transient performance in a timely fashion with equipment that is designed to meet the most stringent requirements

imposed by the end customer. This application note addresses the basics of EMI and transient compliance for military systems that make use of switched-mode power supplies (SMPS). It focuses on basic terms encountered in EMI and transient suppression and on ways to approach the varied requirements of several different military organizations.

ELECTROMAGNETIC INTERFERENCE (EMI)

Electromagnetic interference is divided into in four main classifications:

- 1) conducted emission
- 2) conducted susceptibility
- 3) radiated emission, and
- 4) radiated susceptibility.

Conducted noise is transmitted along the electrical cables that connect the input power bus to the equipment while radiated interference occurs through the unintended transmission or reception of noise signals. EMI emission standards address noise generated by the equipment whereas EMI susceptibility standards describe the noise environments that the equipment must tolerate without malfunction.

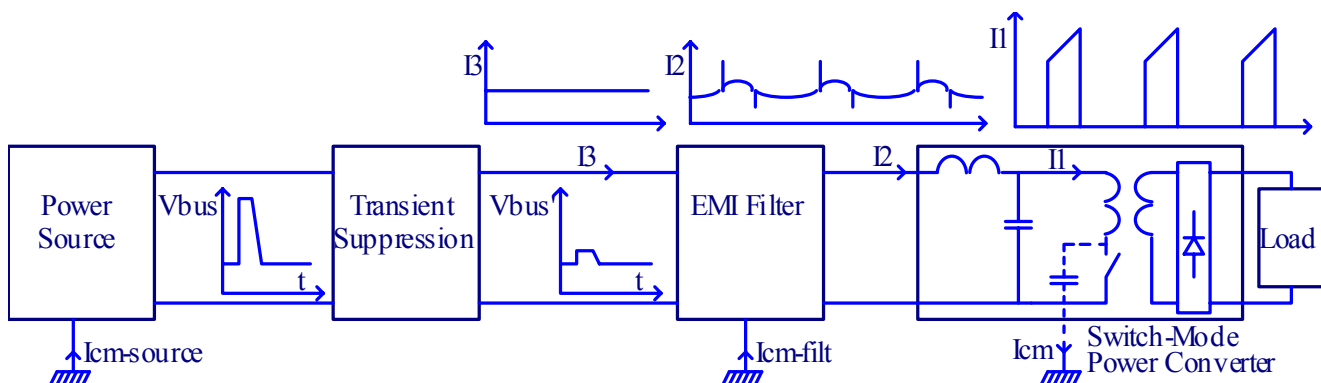
From a design perspective, conducted emissions are further divided into common-mode and differential-mode noise. Differential-mode conducted noise results from currents flowing into one terminal of the converter and out the other,

which is the normal current flow in the circuit¹. Common-mode current, on the other hand, flows through the chassis ground and returns in the same direction in both the power and return lines. Differential-mode current is generally associated with switching currents in the power converter whereas the common-mode currents are primarily a result of pulsating voltages in the circuit.

EMI compliance requires that the system meet standards for all of types of conducted and radiated interference. When one considers the function of an EMI filter, however, it is usually with respect to how well the filter prevents the equipment *emissions* from reaching the main power distribution system. Figure 1 shows a typical SMPS supplied load along with an external EMI filter and transient suppression circuit. The SMPS switching current, I_1 , is attenuated by both the built-in and external filters.

The input current of the SMPS, I_2 , is primarily DC with a specified ripple current component. The ripple component of this current along with the higher frequency spikes are further attenuated by the EMI filter such that the current drawn from the power bus, I_3 , is essentially DC. While I_3 still has a small AC component to it, the filter must be designed to assure that this AC component is below the level specified in the applicable standard. This attenuation of the switching current to a DC level is a measure of the differential-mode performance of the filter. The common-mode effectiveness of the EMI filter is determined by the reduction in the generated common-mode current, I_{cm} , that passes through the source, $I_{cm-source}$. An effective EMI filter must keep the combined common-mode and differential-mode current in the power source leads below specified levels.

Figure 1. Effect of the EMI Filter and Transient Suppression Functions.



¹ For this reason, the terms “common-mode” and “normal-mode” noise are often used interchangeably.

TRANSIENT SUPPRESSION

While EMI filtering is used to attenuate the electrical noise that results from the normal operation of electronic equipment, transient voltage suppression addresses the need to survive infrequent or intermittent disturbances that occur on the power distribution bus. Such power disturbances are caused by the switching of large motors, engine starting, load transients, etc. They are classified as one of three main types:

- 1) voltage ripple
- 2) voltage surges, and
- 3) voltage spikes.

Voltage ripple refers to the variation of the input voltage about a nominal DC input voltage. Surges result from load transients on the power distribution bus and generally last on the order of several milliseconds to 100mS. Spikes, on the other hand, are generally caused by the switching of reactive loads, which induces relatively high-frequency, high-voltage oscillations that last for less than 5mS.

The role of a transient suppression circuit is to protect the EMI filter and in turn the downstream circuitry from damage due to such transients. Figure 1 shows an input bus voltage, V_{bus} , with an input surge superimposed on the nominal DC level. The transient suppressor clamps the input voltage to a level that is safe for the EMI filter and downstream converter, shown as V_{bus} in Figure 1. In this way, the transient suppression function is similar to the EMI filter's susceptibility function: they both protect the load equipment from disturbances that originate on the power distribution bus.

EMI AND TRANSIENT SUPPRESSION STANDARDS

Both EMI and transient suppression are addressed by a number of standards issued by different organizations around the world. For EMI compliance these include the MIL-STD-461 EMI/EMC standard for the US military, RTCA DO-160D for civilian aircraft, and DEF STAN 59-41 for United Kingdom Ministry of Defense applications. Standards that address transients and bus characteristics include MIL-STD-704, MIL-STD-1275, DO-160, and DEF STAN 61-5.

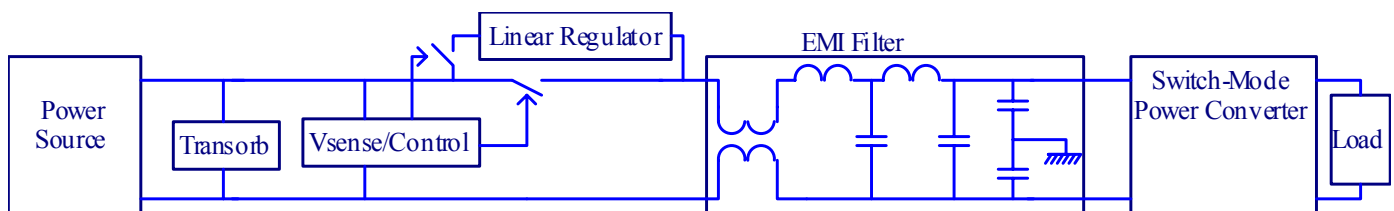
In light of the many standards that apply to EMI compliance and transient suppression, there is good reason to approach the design of a power system by meeting the strictest of the standards wherever possible. Such a "design once, deploy worldwide" approach maximizes the return on development costs and allows for designs that can meet a wider range of end applications. For example, a design that meets MIL-STD-704A specifications for input voltage bus characteristics will usually meet all requirements up to MIL-STD-704E.

TYPICAL DISCREET EMI/TRANSIENT SUPPRESSION SYSTEMS:

The block diagram in Figure 1 shows the basics of a discreet system for transient suppression and EMI filtering. The specific requirements of the different standards must be addressed through the design of each section of the system. Figure 2 shows how the functional blocks of Figure 1 can be

implemented in a typical power system. The transient suppression function uses a linear regulation function that is switched into the circuit when the input voltage exceeds a particular value. When the linear regulator is functioning, the output of the transient suppression circuit is clamped at a regulated value and the difference between the input voltage and the clamp voltage is dropped across the series pass element of the linear regulator.

Figure 2. Transient Protection and EMI Filter Discreet Solution Block Diagram.



Since the power drawn from the source is assumed constant, the dissipation in the linear regulator can be quite high, and this limits the duration of the input transient that can be blocked by the transient protection module. In order to protect the transient protection module, either the input voltage must be limited in time and amplitude or the load must be shut down. The specific performance requirements of the transient specification will dictate the size and power ratings of the transient linear regulator. The transorb element shown in the front of the transient protection circuit protects the circuitry from short duration, limited energy spikes. The transorb voltage must be low enough to provide adequate protection from high-voltage spikes, but must not be so low that longer duration overvoltage conditions damage the transorb itself.

The EMI filter is generally composed of several stages of LC filtering as well as capacitance from

each rail to chassis ground. The LC stages provide differential-mode filtering while the input common-mode choke and output common-mode capacitors determine the filter's common-mode filter performance. The transient protection circuitry is placed in front of the EMI filter. In this way the EMI filter components are protected from the input transient spikes and surges and the EMI filter can be designed to filter the specific load requirement.

EMI/TRANSIENT SUPPRESSION DESIGN SOLUTIONS

PLAN FOR WHERE YOUR DESIGN WILL BE USED

One of the key aspects of successful EMI and transient suppression system design is to plan from the outset for the specific needs of the end market the product will serve. A design that is meant only for the US market may take a very different approach than one intended for Europe or Asia. While most of the EMI and transient standards have similar roots—and some are nearly identical in many respects—it is best to work directly with the specifications for the target market. Note also, however, that the military market is different from the commercial market in that specific performance criteria are often left to the discretion of the program management team. This adds another level of difficulty in that some programs may, for example, require that circuitry operate through particular surge voltages whereas others will allow equipment to shut down and recover for the same input condition. The designer must make sure that such specific operating requirements are clear early in the design process.

UNDERSTAND HOW EMI AND TRANSIENT VOLTAGE TESTS ARE PERFORMED

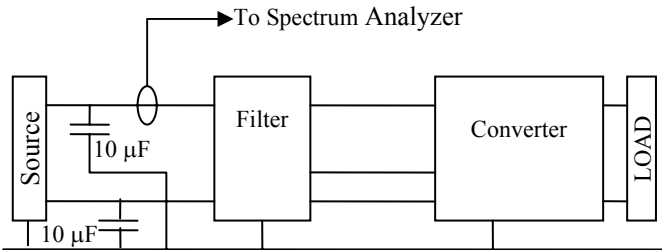
One of the main functions of the various EMI and transient voltage standards is to establish a common technique for the measurement and characterization of EMI performance. Such standards are required in order to make EMI characteristics reproducible from one test lab to another. However, while test conditions are designed to simulate the actual installation environment, the correlation between results in the test lab with those in the field is often difficult to establish.

A further complicating issue for EMI compliance design is that not all standards measure the same characteristic in the same way. For example, MIL-STD-461C measures input conducted emissions using a current probe and states the emissions in terms of $\text{dB}\mu\text{A}$ but MIL-STD-461E uses an input line impedance stabilization network (LISN) and measures noise in terms of $\text{dB}\mu\text{V}$. DEF-STAN 59-41, on the other hand uses a current probe and specifies the emission levels in terms of $\text{dB}\mu\text{A}$, like 461C, but also uses an input LISN like that used in 461E. For this reason, it is necessary to specify the test method used to state the emission levels.

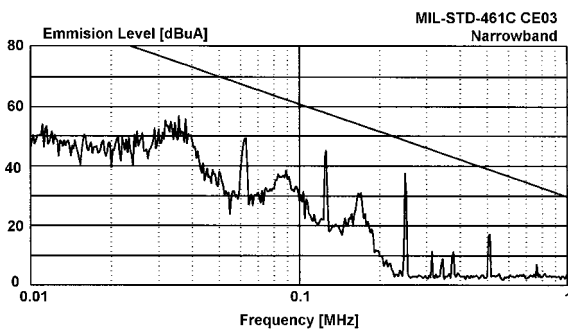
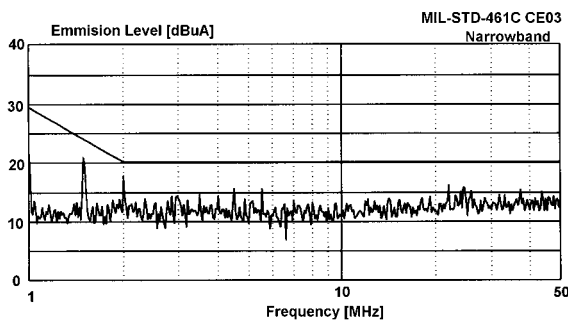
UTILIZE PACKAGED SOLUTIONS THAT ADDRESS YOUR NEEDS

There is considerable work involved in meeting the various EMI and transient suppression requirements spelled out by the different worldwide agencies. This filter design task is often accomplished through the use of discrete filters and one-of-a-kind designs. However, packaged filter solutions that are designed to operate with specific power converters can significantly reduce the time required to achieve a compliant system. In addition, the packaged filter solution can be procured as a single unit, thereby reducing parts count and simplifying the qualification process. The performance of packaged solutions can generally be determined ahead of time and this can increase confidence that a given solution will work for a particular application. Figure 3 and Figure 4 show the conducted EMI and transient performance of VPT's DVMN EMI filter/transient suppression module. This type of information is generally available from module vendors for a variety of application conditions. In addition, application notes and application specific information is available that aids in the use of the packaged filter module for specific situations not covered by the standard datasheet.

**Figure 3 – MIL-STD-461C
DV200-2812D With DVMN28 EMI Filter**

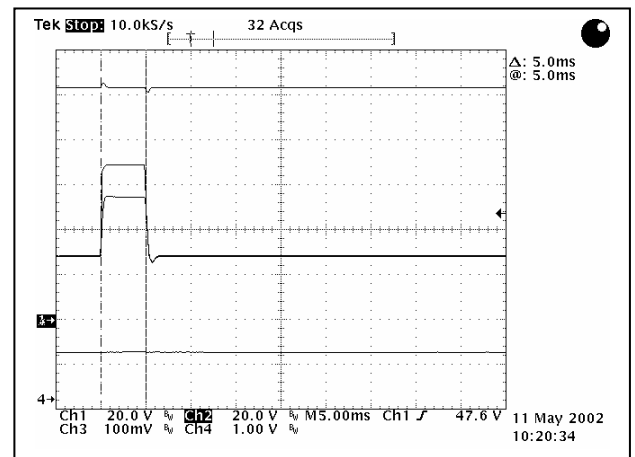


MIL-STD-461 Conducted Emissions

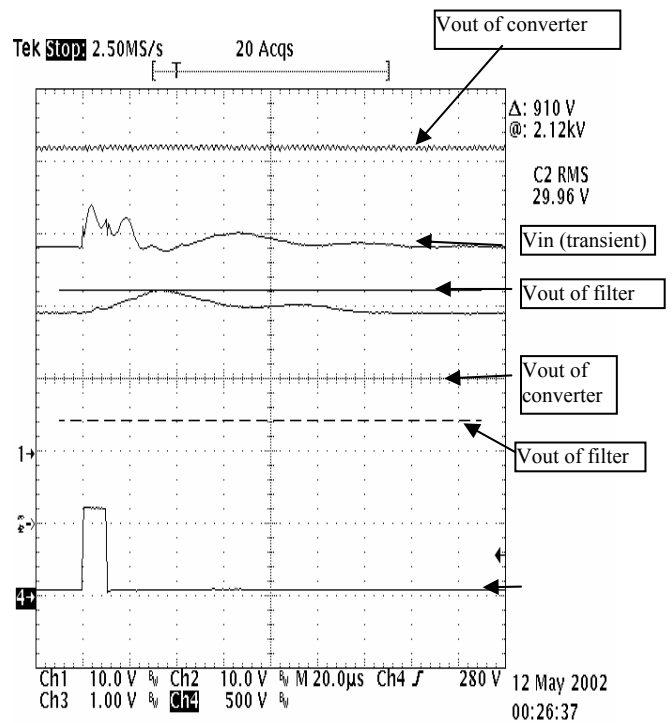


**Figure 4 – Transient Performance of a
Packaged DVMN28 EMI Filter/Transient
Suppression Module with DV200-2812D
Converter**

**Input Transient: 70V/5mS/0.5 ohm
source/Full Load**



**Input Transient: 600V/10uS/Full
Power**



CONCLUSION

EMI filtering and transient suppression are needed in military systems to ensure that

- 1) the various electrical components do not generate excessive electrical disturbances that will impact other equipment, and
- 2) all electrical components attached to the power bus can tolerate and/or operate through the power bus disturbances that are typical for given operating environments.

Several different sets of EMI and voltage transient specifications have been established over the years to address these requirements. In some cases the standards from the various agencies are very similar and in other cases they are quite different either in the methods used to test the equipment for compliance or in the actual levels of the interference signals. Solutions that meet as many of the performance standards as possible result in hardware that can be used in a variety of locations worldwide. The designer must realize, however, that a design that meets the requirements of many different specifications is usually over-designed (and therefore more expensive, larger and heavier) for some applications. It is therefore necessary to trade off the overall performance of a system with the specifics of each application and the schedule requirements of the project. Nonetheless, packaged EMI/Transient suppression modules tailored for the load converters they supply can offer a significant advantage in addressing the conflicting needs for rapid system development, wide-ranging end use and efficient packaging.

ADDITIONAL INFORMATION

For additional information on EMI and transient voltage spike suppression, or to learn about VPT's products for EMI and voltage spike suppression, contact VPT at 425.487.4850 or sales@vpt.com. Or, visit VPT at www.vpt-inc.com.

Dr. Glenn Skutt is the Vice President of Technology for VPT, Inc.