

## Part Number & Ordering Information

### Marking

Style  
Capacitance & tolerance  
Voltage  
Logo  
Date Code  
(Order of markings may vary depending on size of the capacitor)

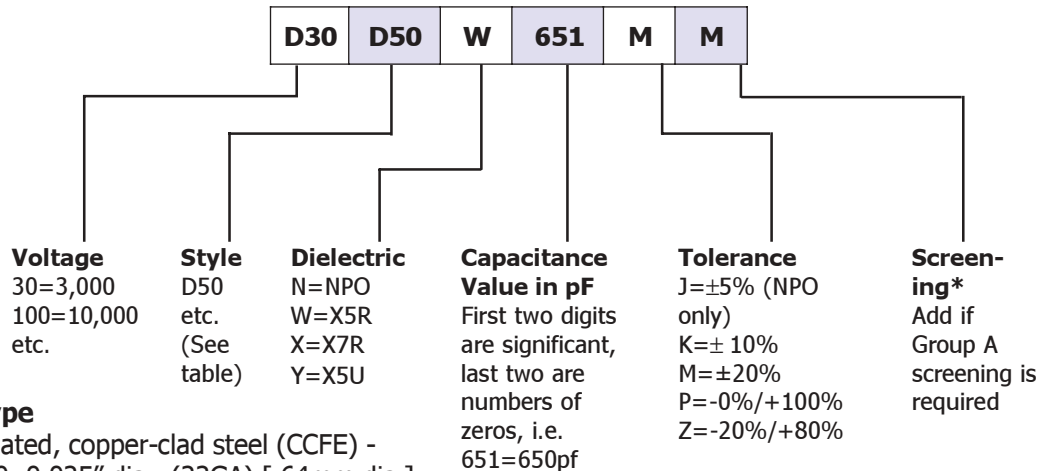

### Lead Type

Solder plated, copper-clad steel (CCFE) -  
D30, D40: 0.025" dia. (22GA) [.64mm dia.]  
D50 & larger: 0.032" dia. (20GA) [.81mm dia.]

### General Information

Disc capacitors are designed and manufactured under strict quality control guidelines in order to insure performance and reliability for high voltage applications.

Double action pressing is utilized to minimize density gradients and produce uniform fired ceramic density. Capacitors are available screened to MIL-PRF-49467 established reliability specification.

### Installation

Higher-voltage parts may require further encapsulation to prevent surface breakdown. Parts should be cleaned and oven dried at 85°C before further encapsulation. Silicone rubbers or an epoxy may be used. De-airing of encapsulates is recommended.

During installation soldering we recommend attaching a heat sink to the lead between the soldering iron and capacitor. Components should be preheated to approximately 120°C prior to heat sink attachment.

Testing higher-voltage parts before encapsulation may be done in a suitable dielectric fluid such as FC-40.

### Testing & Screening Information

- Dielectric withstanding voltage to Mil-Prf-49467, Mil-Std-202, MTD 302
- Insulation Resistance 25°C to Mil-Prf-49467, Mil-Std-202, MTD 302
- Capacitance/Dissipation Factor to Mil-Prf-49467, Mil-Std-202, MTD 305
- Group A & B inspection to Mil-Prf-49467, DSCC 87125, DSCC 89087, and NASA GSFC S-311-P-15C, where applicable.



# High Voltage Disc Ceramic Capacitors Leaded and Coated

3kV to 20kV

## High Voltage Disc Ceramic Capacitors

### Dielectric Comparison

SPECIFICATION	DIELECTRIC TYPE (EIA DESIGNATION)			
	NPO	X5R	X7R	X5U
TEMPERATURE RANGE	-55°C to 125°C	-55°C to 85°C	-55°C to 125°C	-55°C to 85°C
TEMPERATURE COEFFICIENT	± 30ppm/°C	±15%	±15%	+22%/-56%
VOLTAGE COEFFICIENT	0	-25% @ rated voltage and temperature	-25% @ rated voltage and temperature	N/A
VOLTAGE RANGE	3kV to 20kV	3kV to 20kV	3kV to 20kV	3kV to 20kV
DIELECTRIC WITHSTANDING VOLTAGE TEST	3kV to 20kV 1.5x rated	3kV to 20kV 1.5x rated	3kV to 20kV 1.5x rated	3kV to 20kV 1.5x rated
IR @ 25°C	100,000MΩ or 1,000MΩ - μF whichever is less	100,000MΩ or 1,000MΩ - μF whichever is less	100,000MΩ or 1,000MΩ - μF whichever is less	100,000MΩ or 1,000MΩ - μF whichever is less
IR @ EVALUATED TEMPERATURE	10,000MΩ or 100MΩ - μF whichever is less @ 125°C	10,000MΩ or 100MΩ - μF whichever is less @ 85°C	10,000MΩ or 100MΩ - μF whichever is less @ 125°C	10,000MΩ or 100MΩ - μF whichever is less @ 85°C
DISSIPATION FACTOR @ 1kHz, 25°C	0.1% max	2.5% max	2.5% max	2.5% max
AGING RATE	0	-2% max/decade hour	-2% max/decade hour	-3% max/decade hour
COEFFICIENT OF THERMAL EXPANSION @ 25°C	9x10 <sup>-6</sup> in/in/°C	11x10 <sup>-6</sup> in/in/°C	11x10 <sup>-6</sup> in/in/°C	11x10 <sup>-6</sup> in/in/°C

VOLTAGE RATING (kV)	MAX THICKNESS INCHES [MM]
3	0.15 [3.8]
5	0.20 [5.1]
7.5	0.28 [7.1]
10	0.35 [8.9]
15	0.45 [11.4]
20	0.55 [14.0]

**Calramic Technologies LLC**  
 P) 775.851.3580  
 (F) 775.851.3582  
 E-mail: [info@calramic.com](mailto:info@calramic.com)

3555 Airway Drive #306  
 Reno, NV 89511 USA  
<http://www.calramic.com>



# High Voltage Disc Ceramic Capacitors Leaded and Coated

3kV to 20kV

## High Voltage Disc Ceramic Capacitors

	DISC STYLE	D MAX.	S +/- .030	NPO (PF)		X5R (PF)		X7R (PF)		X5U (PF)	
				MIN.	MAX.	MIN.	MAX.	MIN.	MAX.	MIN.	MAX.
3kVDC	D30	.30	.250	8.0	9.6	270	330	240	290	540	650
	D40	.40	.250	12	15	420	500	370	440	830	1000
	D50	.50	.375	19	23	650	780	580	690	1310	1570
	D60	.60	.375	38	45	1300	1600	1100	1400	2500	3100
	D80	.80	.500	75	90	2600	3100	2300	2700	5200	6200
	D90	.90	.500	110	130	3800	4500	3300	3900	7500	9000
	D100	1.00	.500	150	180	5100	6100	4500	5400	10200	12000
	D120	1.20	.500	200	240	6600	8000	5900	7000	13300	16000
	D140	1.40	.625	310	370	10400	12500	9000	11000	21000	25000

	DISC STYLE	D MAX.	S +/- .030	NPO (PF)		X5R (PF)		X7R (PF)		X5U (PF)	
				MIN.	MAX.	MIN.	MAX.	MIN.	MAX.	MIN.	MAX.
5kVDC	D30	.30	.250	4.8	5.9	160	200	140	175	320	400
	D40	.40	.250	7.3	9	250	300	220	270	490	610
	D50	.50	.375	12	14	390	480	340	420	780	960
	D60	.60	.375	23	28	760	940	670	830	1500	1900
	D80	.80	.500	46	57	1600	1900	1300	1700	3100	3800
	D90	.90	.500	66	81	2200	2700	1900	2400	4500	5500
	D100	1.00	.500	90	110	3000	3700	2600	3300	6100	7500
	D120	1.20	.500	120	150	3900	4900	3500	4300	7900	9800
	D140	1.40	.625	180	230	6200	7700	5500	6700	12400	15300

	DISC STYLE	D MAX.	S +/- .030	NPO (PF)		X5R (PF)		X7R (PF)		X5U (PF)	
				MIN.	MAX.	MIN.	MAX.	MIN.	MAX.	MIN.	MAX.
7.5kVDC	D30	.30	.250	3.2	3.9	110	130	95	120	220	260
	D40	.40	.250	4.9	6	170	200	150	180	330	400
	D50	.50	.375	7.6	9.4	260	320	230	280	520	630
	D60	.60	.375	15	18	510	620	450	550	1000	1200
	D80	.80	.500	31	37	1000	1200	900	1100	2100	2500
	D90	.90	.500	44	54	1500	1800	1300	1600	3000	3600
	D100	1.00	.500	60	73	2000	2400	1700	2100	4100	5000
	D120	1.20	.500	78	96	2600	3200	2300	2800	5300	6600
	D140	1.40	.625	120	150	4100	5000	3600	4500	8300	10100

**Calramic Technologies LLC**  
 P) 775.851.3580  
 (F) 775.851.3582  
 E-mail: [info@calramic.com](mailto:info@calramic.com)

3555 Airway Drive #306  
 Reno, NV 89511 USA  
<http://www.calramic.com>



# High Voltage Disc Ceramic Capacitors Leaded and Coated

3kV to 20kV

## High Voltage Disc Ceramic Capacitors

	DISC STYLE	D MAX.	S +/- .030	NPO (PF)		X5R (PF)		X7R (PF)		X5U (PF)	
				MIN.	MAX.	MIN.	MAX.	MIN.	MAX.	MIN.	MAX.
10kVDC	D30	.30	.250	2.4	2.9	80	100	70	90	160	200
	D40	.40	.250	3.7	4.5	120	150	110	130	250	300
	D50	.50	.375	5.7	7.1	200	240	170	210	390	470
	D60	.60	.375	11	14	380	470	330	410	760	930
	D80	.80	.500	23	28	770	950	680	830	1550	1900
	D90	.90	.500	33	41	1100	1400	980	1200	2200	2700
	D100	1.00	.500	45	55	1500	1900	1300	1700	3100	3700
	D120	1.20	.500	59	72	2000	2400	1800	2100	3900	4800
	D140	1.40	.625	92	110	3100	3800	2800	3300	6200	7600
15kVDC	D30	.30	.250	1.6	2	55	65	50	60	110	130
	D40	.40	.250	2.4	3	80	100	75	90	170	200
	D50	.50	.375	3.8	4.7	130	160	110	140	260	320
	D60	.60	.375	7.5	9.2	250	310	220	270	510	620
	D80	.80	.500	15	19	520	630	450	560	1100	1260
	D90	.90	.500	22	27	740	910	650	800	1500	1800
	D100	1.00	.500	30	37	1000	1200	900	1100	2100	2500
	D120	1.20	.500	40	48	1300	1600	1200	1400	2700	3200
	D140	1.40	.625	62	75	2100	2500	1800	2200	4200	5000
20kVDC	D30	.30	.250	1.2	1.5	40	50	35	40	80	100
	D40	.40	.250	1.8	2.2	60	75	55	65	120	150
	D50	.50	.375	2.9	3.5	100	120	85	100	190	240
	D60	.60	.375	5.6	6.9	190	230	170	200	380	460
	D80	.80	.500	12	14	390	470	340	420	780	950
	D90	.90	.500	17	20	560	680	490	600	1120	1350
	D100	1.00	.500	23	28	760	930	670	820	1520	1850
	D120	1.20	.500	30	36	1000	1200	870	1100	2000	2400
	D140	1.40	.625	46	56	1500	1900	1300	1700	3100	3800

0803

**Calramic Technologies LLC**  
 P) 775.851.3580  
 (F) 775.851.3582  
 E-mail: [info@calramic.com](mailto:info@calramic.com)

3555 Airway Drive #306  
 Reno, NV 89511 USA  
<http://www.calramic.com>